

MODEL: M3-105-85-i34-B24V-SI96_MX
 SUPPLY: 540V_{DC} / 65A_{RMS}

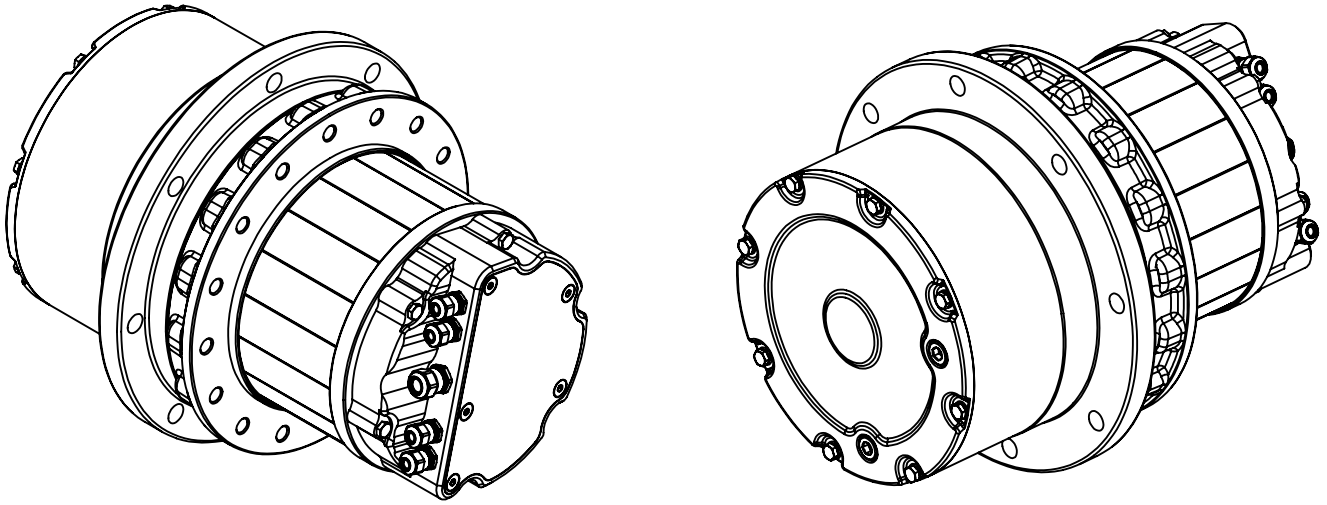

DRIVE PERFORMANCE

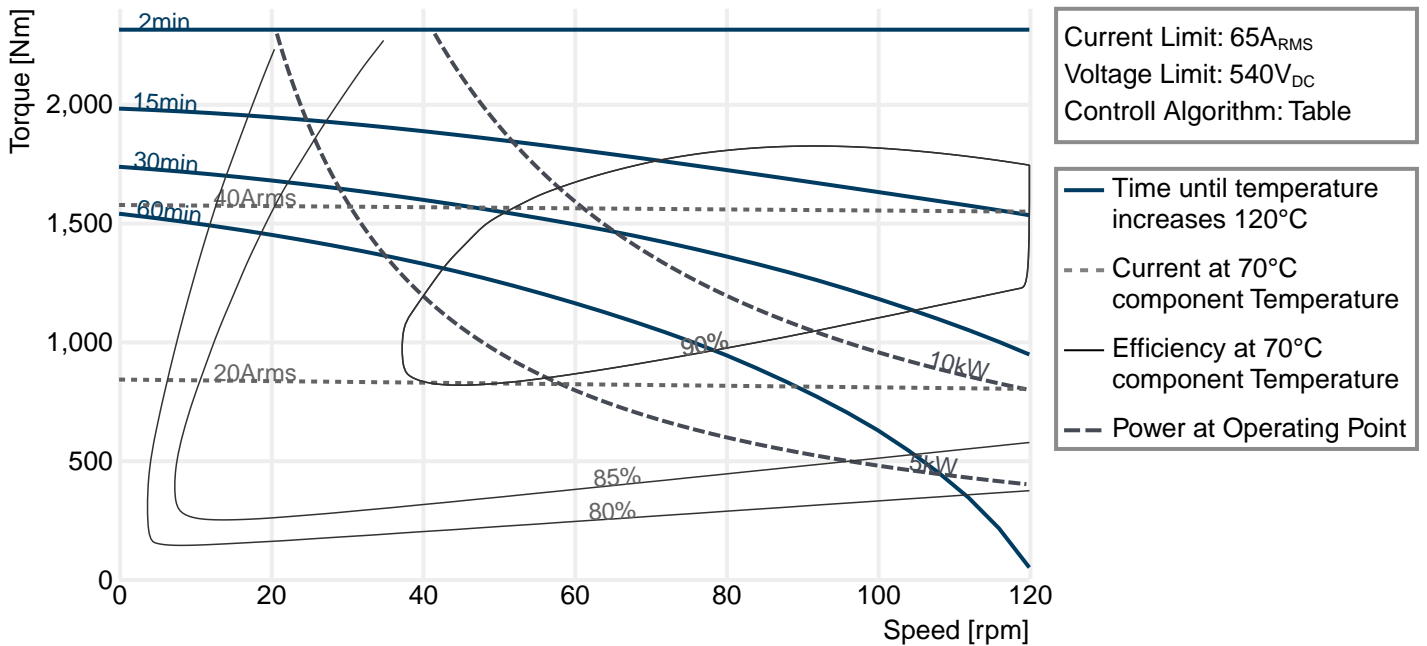

Engine Type	IPM	
Number of Poles	12	
Reducer Ratio	34.00	
Peak Torque (Flange)	2312 Nm	
Peak Current	61 Arms	
Torque Constant (Shaft / Flange)	1.21 Nm/Arms	41.1 Nm/Arms
Back EMF Const. (Line to Line @ motor shaft)	PEAK: 103.4 V/1000min-1	RMS: 73.1 V/1000min-1
Electrical Resistance @ 25°C	74 mOHM	
Electrical Inductance	Lq: 2.79 mH	Ld: 2.29 mH

BRAKE

Brake Type	Negative Type Electric Disk Brake
Function Principle	Braked Engine Shaft
Nominal Voltage	24VDC
Typ. Braking Torque	2312 Nm
Typ. Resistance	13 OHM
Brake Type	Negative Type Electric Disk Brake

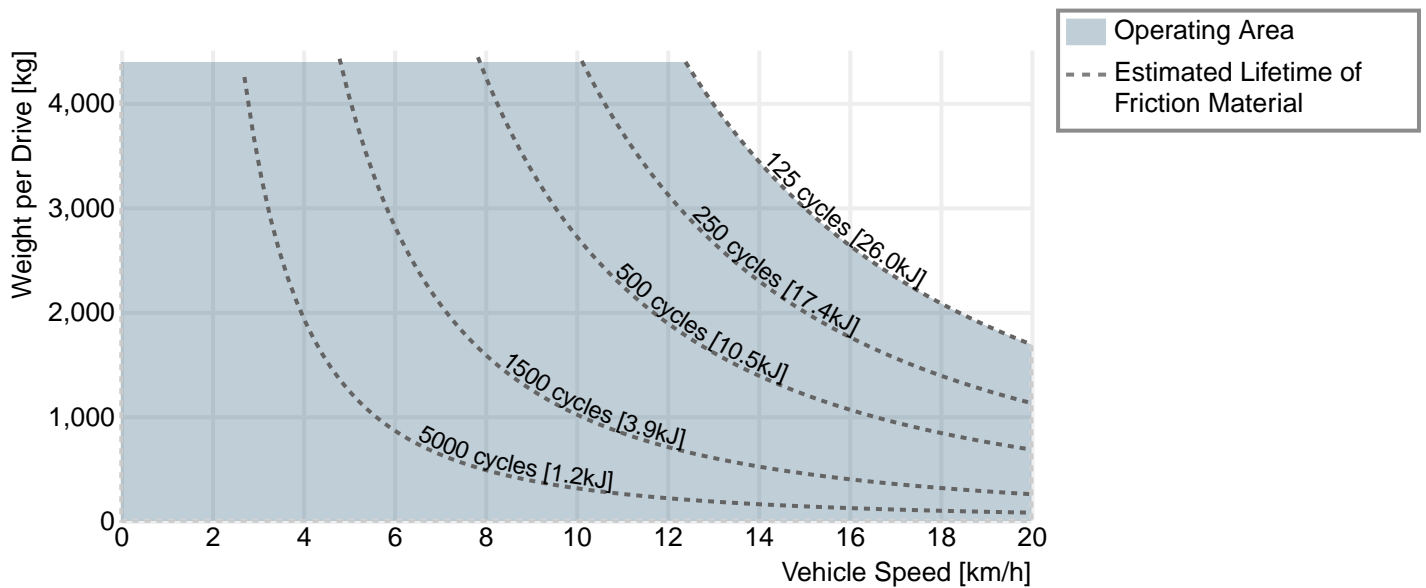

The number of possible cycles has been evaluated with flywheel-tests. The number of possible cycles in the real application will also depend on the inclination. The condition of the brake must be checked in the application

DIMENSIONS

SIDE VIEW

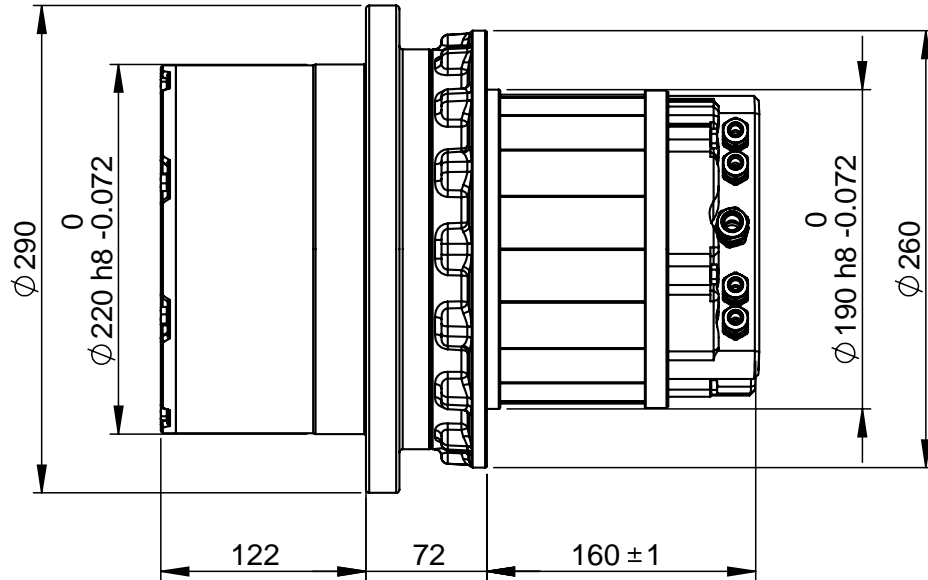

ROTATING FLANGE

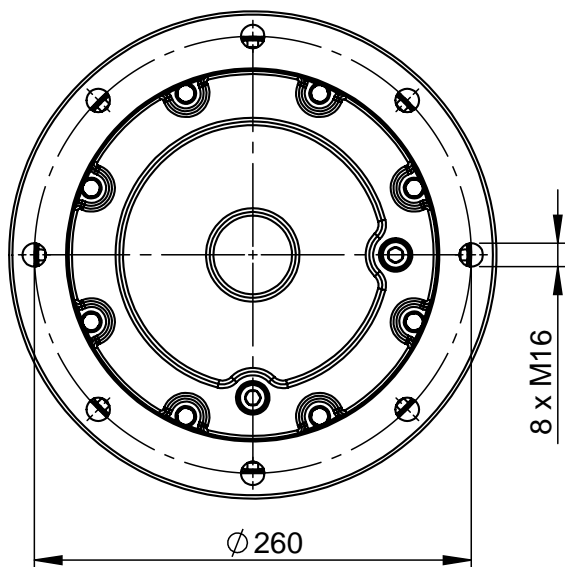

FIXED FLANGE

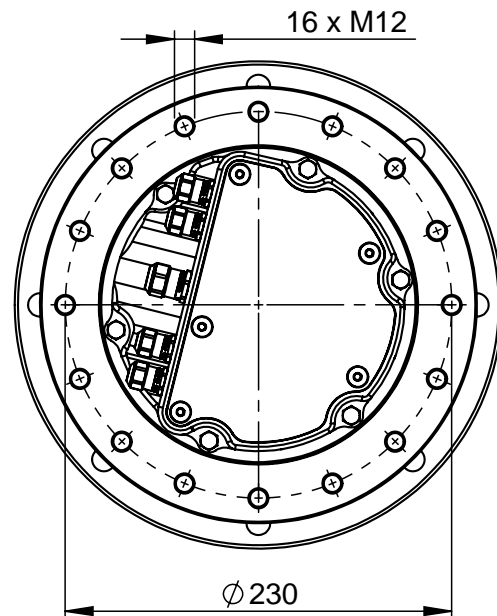

SENSOR

Absolute binary synchro-serial (SSI) + Incremental, RS422

Power supply	Vdd = 5 V ±5 %
Current consumption	Max. 35 mA
Incremental outputs	A, B, Z, A-, B-, Z- (RS422)
Data output	Serial data (RS422)
Data input	Clock (RS422)
Resolution	4096 cpr

Timing Diagram - SSI

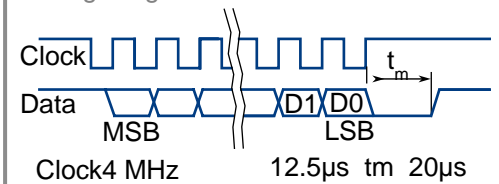

Timing Diagram - Incremental

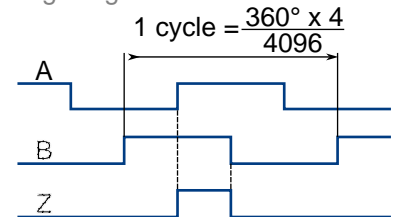

Recommended Signal Termination
For data output lines

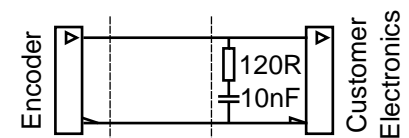

TEMPERATURE SENSOR

Sensor Type	PT1000
Number of Sensors	1x
Position of Temperature Sensor	Encapsulated between stator winding

Table of the Resistance values:

-40 °C	843 OHM
-30 °C	882 OHM
-20 °C	922 OHM
-10 °C	961 OHM
0 °C	1000 OHM
10 °C	1039 OHM
20 °C	1078 OHM
30 °C	1117 OHM
40 °C	1155 OHM
50 °C	1194 OHM
60 °C	1232 OHM

60 °C	1232 OHM
70 °C	1271 OHM
80 °C	1309 OHM
90 °C	1347 OHM
100 °C	1385 OHM
110 °C	1423 OHM
120 °C	1461 OHM
130 °C	1498 OHM
140 °C	1536 OHM
150 °C	1573 OHM
160 °C	1611 OHM

CONNECTIONS

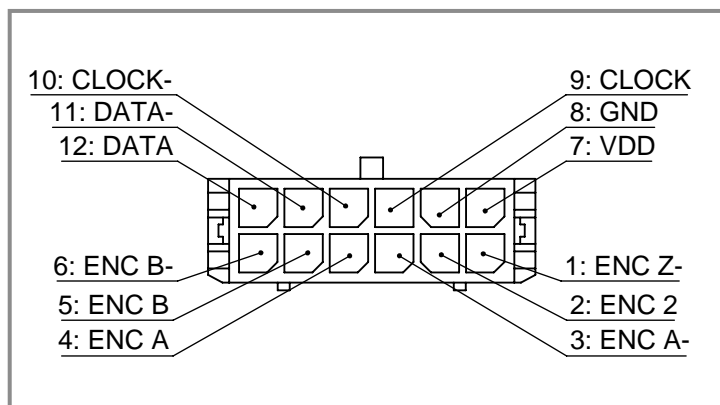
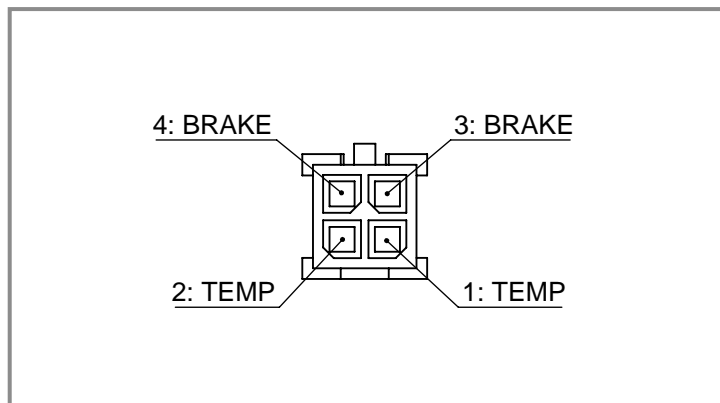
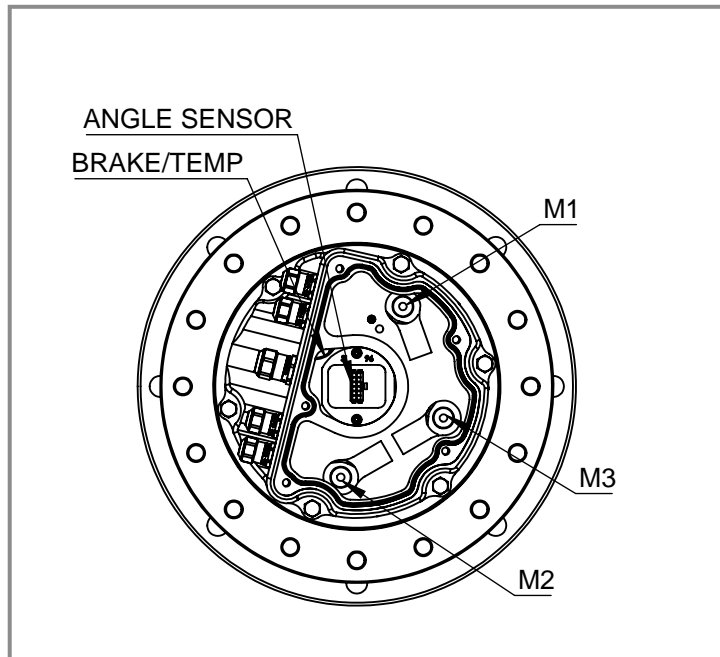

Mating Power Connectors

	Part	Progress EMV
	Mfg #	1083.17
	I&W #	P0003_0417
	Mfg	AGRO

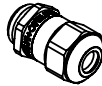
	Part	Progress EMV
	Mfg #	1083.12.065
	I&W #	P0003_0418
	Mfg	AGRO

Mating Signal Connectors

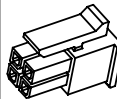
	Part	Housing
	Mfg #	43020-0401
	I&W #	P0052_0039
	Mfg	Molex

	Part	Terminal
	Mfg #	43030-0009
	I&W #	P0052_0063
	Mfg	Molex

Mating Signal Connectors

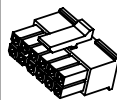
	Part	Housing
	Mfg #	43025-1200
	I&W #	P0052_0026
	Mfg	Molex

	Part	Terminal
	Mfg #	43030-0009
	I&W #	P0052_0063
	Mfg	Molex